



Simulation of natural convection flow for vertical heated rod by using ANSYS/Fluent

Thanh Tung Duong¹, Tan Hung Hoang², Hoang Tuan Truong³, Chi Thanh Tran⁴, Hiroshige Kikura⁵

¹Nuclear Training Center, Vietnam Atomic Energy Institute; duongttung@gmail.com;

²Chungnam National university; hoangtanhung@o.cnu.ac.kr

³Centre for Nuclear Technologies; truong.hoang.tuan@cenutech.vn

⁴Vietnam Atomic Energy Institute; tranchithanh@vinatom.gov.vn

⁵Laboratory for Zero-Carbon Energy, Institute of Innovation Research, Tokyo Institute of Technology, Japan; Email: kikura.h.aa@m.titech.ac.jp

Abstract: The decay heat removal by natural convection is very important in case of Station blackout (SBO) of a nuclear reactor. The computational fluid dynamic (CFD) is helpful to simulate the flow and temperature field. However, the CFD simulation models need to be validated by the experimental data. Thus, in this report, the Ansys/Fluent is applied to simulate the natural convection induced by single heater rod. The vertical heated rod with a diameter of 12 mm and the length of 225 mm was immersed at the center of a vertical pipe made of acrylic with a diameter of 150 mm and a height of 500 mm. In this simulation, the coupled scheme algorithm was also applied. Regarding to experimental method, the optical method such as Particle Image Velocimetry (PIV) was applied for 2-dimensional velocity distribution. The k-type thermocouple was used to measure the pointwise temperature history. As a result, the predicted flow and temperature field had a good agreement with experimental data. Accordingly, the thermal plumes were well estimated by using ANSYS/Fluent, in which the buoyant plumes induced by different temperatures vertically went up along the heater rod's upper part until the container's isolated upper wall. The complicated flow occurred in the middle part of the container by mixing the downward flow on the top and the upward flow from the heater rod.

Keywords: *Natural convection flow, Ansys/Fluent, PIV, research reactor*

I. INTRODUCTION

In nuclear research reactor, the thermal-hydraulic design aim to ensure the cooling of the reactor core and the integrity of core is maintained during the normal operation, abnormal operational transient or incident/accidents. There are multipurpose in using research reactor such as material research by doing irradiation, radio-isotope production, and so on. In pool type reactor, both natural and forced convection were used to cool the reactor core [1]. Thus, the thermal natural convective

flows occur in a water pool attracted large attention. In order to understand the thermal-hydraulic design, the system computer code (Relap5, ...) was used to simulate the behavior of the reactor system to ensure that a balance between energy removal from the fuel to the coolant. However, it was difficult to understand the heat removal of fuel element by using the system codes by modelling core as a pipe. Therefore, the computational fluid dynamic (CFD) such as Ansys/Fluent is useful to simulate the flow though the narrow gap and complicated geometry. The CFD simulation

need to be validated by experimental data. Recently, various experimental tests [2-5] have been built up by applying the advanced measurement technique to observe the natural convection flow behavior induced heater rod for a deep understanding. Kitamura et al. [2] has investigated the effect of an array horizontal cylinder heater using air as working fluid and they derived the new correlation of heat transfer with low Rayleigh number (10^5). They found the the plume remained laminar if the gap between the heater rod was less than 20.6 mm. Stig et al. [3] has investigated the transition from laminar to turbulent flow of horizontal heater rod when using the water with the Rayleigh number around 10^7 . They found that the non-laminar flow behavior a distance above the cylinder. The structure in turbulent flow in which the dissipation energy from larger-scale circulation to small scale has been investigated by Park et al. [4] from a single horizontal heater rod by using optical method. The thermal stratification in pool boiling of a horizontal cylinder heater rod has been reported by Kim et al. [5]. They discussed thermal stratification and stagnant region depending on the pool temperature. However, the previous studies focused on the flow structure of natural convection by horizontal heater rod experimentally. Therefore, the convective natural flow of vertical is needed to for further application of nuclear reactor fuel rod.

Nguyen et al. [6] investigated the operational condition of a 10 MW research reactor with various system codes to verify this reactor's conceptual design. However, the detailed information on the flow and heat removal through a narrow gap of fuel elements still needs to be included. The ANSYS/Fluent, can readily estimate this essential phenomenon. Still, it is challenging to model a three-dimensional whole core due to the complex

geometry and scale requiring considerable computation. Furthermore, the temperature dependence of physical properties (viscosity, thermal expansion, thermal conductivity and specific heat) is often ignored. Therefore, in this research, the simulation of the natural convection flow of a single rod experiment was performed by considering the coupled-scheme for those physical properties in each time step. The spatial information of fluid flow and temperature in three dimensions is essential to understanding the convective flow. Therefore, in this report, the convective natural flow induced by a single vertical heater rod was simulated by ANSYS/Fluent and the simulation results were confirmed with the experimental data in which the 2-dimensional velocity profile was measured by Particle Image Velocimetry (PIV) method.

II. EXPERIMENTAL APPARATUS AND NUMERICAL PROCEDURE

A. Experimental apparatus of natural convection

The main test section was the vertical heated rod with a diameter of 12 mm and the length of 22.5 mm. The wild rod was immersed at the center of a vertical pipe made of transparent acrylic with an inner diameter of 150 mm and a height of 500 mm. The transparent acrylic had a thickness of 3 mm for illumination and image acquisition. The working fluid was water; the initial temperature (T_{in}) was kept at room temperature (27 °C). The power set to the heater rod was 100 W, corresponding to a heat flux of 11864 W/m^2 . Nylon powder ($d=80 \text{ }\mu\text{m}$; $\rho = 1020 \text{ kg/m}^3$) was dispersed in working fluid as reflector particles for PIV (Particle Image Velocimetry) measurements (Figure 1). A camera with 60 fps was used to record the movement of particles illuminated by a laser sheet. This data allowed one to analyze the 2-dimensional velocity distribution by using the PIV method.

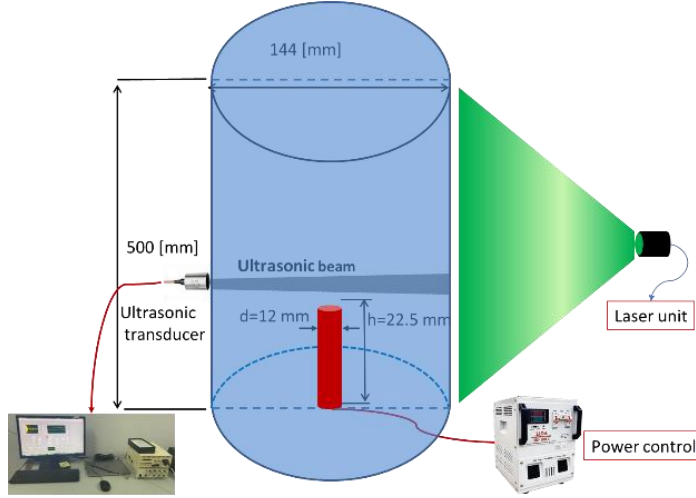

Fig. 1. Sketch of vertical heated rod natural convection and test section for measurement. The number shows the length in mm

The flow behavior and temperature history were selected to compare the simulation results and the turbulence model. The pointwise temperature at $(x^*=-72, y^*=7.5, z^*=0)$ (T4) and $(x^*=-72, y^*=7.5, z^*=0)$ (T3) were measured using k-type couple. Besides, the PIV method was applied to visualize the measured 2-dimensional flow field inside the container.

B. Rayleigh number

In natural convection, the Rayleigh number was used to estimate the flow regime. And, the power heater rod was selected similarity as in the research reactor (10^5 - 10^9) since the convective flow relates to the heat transfer from the heater rod to the water, the modified Rayleigh number (Ra^*) was used to identify the flow regime based on the heat flux density [7]. The Ra was calculated as follows:

$$Ra^* = \frac{g\beta qL^4}{k\nu\alpha} \quad (1)$$

Where g is the acceleration due to gravity, β is the thermal coefficient of expansion, q is the heat flux density, L is the characteristic length of the heater rod in the direction of gravity, k is the thermal

conductivity, ν is the kinematic viscosity, α is the thermal diffusivity. Thus, the modified Rayleigh number in our current experiment condition was $1,025 \times 10^8$.

C. Numerical modelling

1. Governing equation of Ansys/Fluent

The governing equations for conservation of the mass, momentum, and energy can be written as follows:

Continuity equation

$$\frac{\partial \rho}{\partial t} + \nabla \cdot (\rho \vec{v}) = 0 \quad (2)$$

Where $\rho = \rho(x, y, z, t)$ is the density and \vec{v} is the velocity vector.

Momentum equation

The momentum relation in differential form is expressed as follows:

$$\frac{\partial}{\partial t} (\rho \vec{v}) + \nabla \cdot (\rho \vec{v} \vec{v}) = -\nabla p + \nabla \cdot (\bar{\tau}) + \rho \vec{g} \quad (3)$$

With total pressure p and gravitational vector \vec{g} . The shear stresses $\bar{\tau}$ due to the fluid molecular viscosity μ .

$$\bar{\tau} = \mu \left[(\nabla \vec{v} + \nabla \vec{v}^T) - \frac{2}{3} \nabla \cdot \vec{v} I \right] \quad (4)$$

And I is just a unit tensor.

Energy equation

$$\frac{\partial}{\partial t}(\rho E) + \nabla \cdot (\vec{v}(\rho E + p)) = \nabla \cdot (k_{eff} \nabla T + (\bar{\tau}_{eff} \cdot \vec{v})) + S_h \quad (5)$$

Where k_{eff} , $\bar{\tau}_{eff}$, S_h are the effective conductivity, effective shear stresses, and volumetric heat sources.

$$E = h - \frac{p}{\rho} + \frac{v^2}{2} \quad (6)$$

The enthalpy h is defined as follows.

$$h = \int_{T_{ref}}^T C_p dT \quad (7)$$

Where C_p is the specific heat at constant pressure.

There are three different approaches in the computational fluid dynamics study of turbulent flow: Direct Numerical Simulation (DNS), Large-eddy simulation (LES, and Reynolds averaged Navier-Stokes equation (RANS). The DNS approach involves calculating instantaneous turbulent variables, such as the approach uses no approximation, and the simulation produces the fundamental characteristic of turbulence, but the computational cost is very high. Therefore, to reduce that cost, the standard method for industrial simulation is the RANS method, based on the Reynolds decomposition

2. Modelling and simulation using Ansys/Fluent

In order to simulate the natural convection flow induced by a heated rod, the 3-dimensional geometry was created like the experimental apparatus. Seok-ki Choi et al. [8] recommended using the k- ϵ turbulence model to simulate natural convection. A turbulence intensity of 5% was fixed in this simulation. The Coupled scheme algorithm was selected instead of the Segregated

Scheme in Fluent Solver. The simulation for natural convection in the vertical heated rods was performed by ANSYS/Fluent 17.2 using Windows 10 Intel Core i7 with 32 GB of RAM, as shown in Fig. 3.

The mesh was created appropriately using the three materials (heater rod, wall adiabatic, and water as working fluid). The meshes near the heater rod were defined finer due to the temperature change quickly. For this study, 80000 nodes and 78000 elements are applied for this mesh creation method. The boundary and initial conditions (i.e., heat flux, thermal isolation) were selected similarly to the experiment.

Since the Ra was high. The standard k-epsilon model was used. In natural convection, the temperature change in the physical properties below was modeled as a function of temperature as follows [9]:

$$\mu = \frac{-0.00018576T^3 + 0.197172T^2 - 70.15T + 8401.04}{100000} \quad (8)$$

$$C_p = 0.0092T^2 - 5.6859T + 5058.24 \quad (9)$$

$$k = -0.00000905T^2 + 0.007048T - 0.6893 \quad (10)$$

$$\beta = -0.000000029783(T - 273.15)^2 + 0.0000103247(T - 273.15) + 0.00000755683 \quad (11)$$

Since the Ansys/Fluent Bousiness density model does not allow thermal expansion β as a function of temperature T , it was necessary to derive a new density model with temperature as an independent variable. The custom density model was governed by Bousinesq approximation.

$$\rho = \rho_{ref}(1 - \beta(T - T_{ref})) \quad (12)$$

This density model ultimately made the Reynold-averaged Navier-Stokes (RANS) become a Favre-averaged Navier-Stokes.

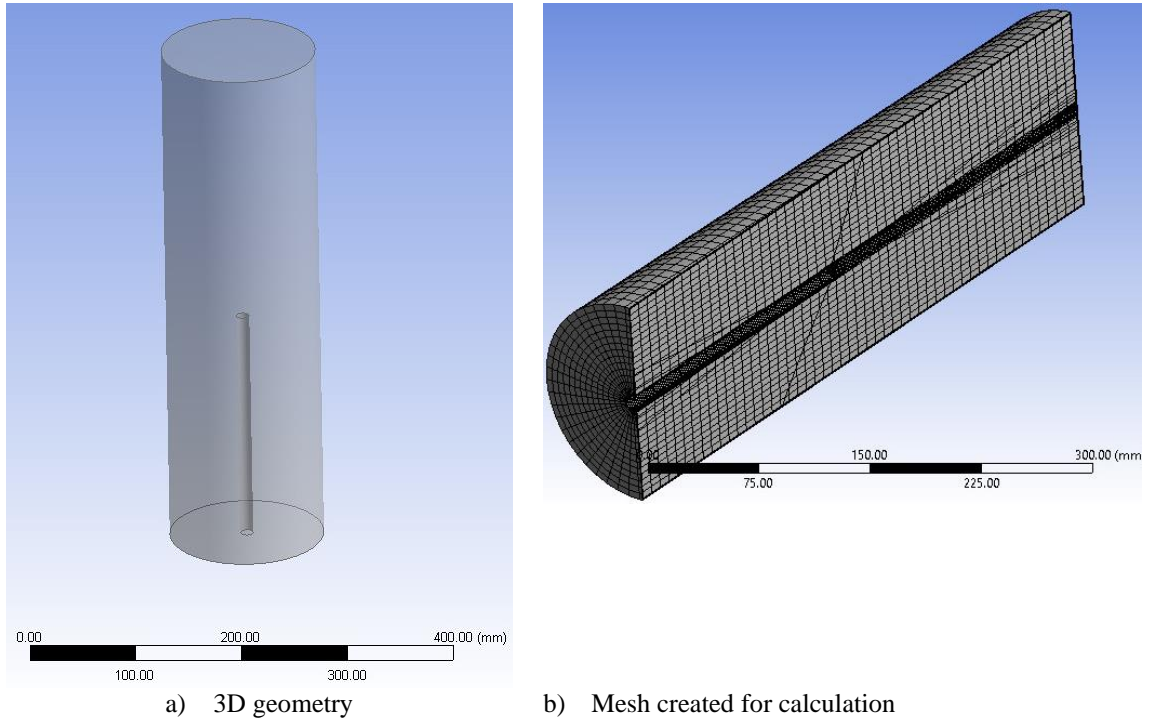

Fig. 3. Geometry and mesh of calculation using ANSYS/Fluent

III. RESULTS

A. Experimental results

The flow was visualized using the PIV method to confirm the simulation model. After 5 minutes (300 s), the velocity was measured and synchronized with the PIV method. The buoyant flow induced by the heater rod went up and was concentrated at the center upward of the rod. Flow near the pipe wall was very low. This result was confirmed by 2-dimensional velocity distribution using the PIV method in Figure 4.

The flow was also visualized by image processing to understand the flow structure. The flow immensely fluctuates, as confirmed by the temperature profile. Fig. 4 showed the typical natural flow induced by the heater rod. The upward flow along the heater rod was very clearly observed. The density of water near the heater rod decreased and went to the colder region due to the buoyancy force. The water

descended when reaching the upper wall. Therefore, in the upper area of the heater rod and the upper part of the container, the upward and downward flow induced a highly complex flow behavior in which energy dissipation and transfer must be investigated. The results showed that the plume mainly concentrates on the region near the heater rod.

B. Simulation results

The flow behavior was firstly visualized in 2-D to compare with image processing from experimental data qualitatively. Fig. 4 showed the complicated flow with two big vortices observed at the middle upper part of the container. The upward flow along the heater rod is very clearly marked. The density of water near the heater rod decreased and went to the colder region due to the buoyancy force. The pointwise temperature was compared

between the experiment and simulation data (figure 5).

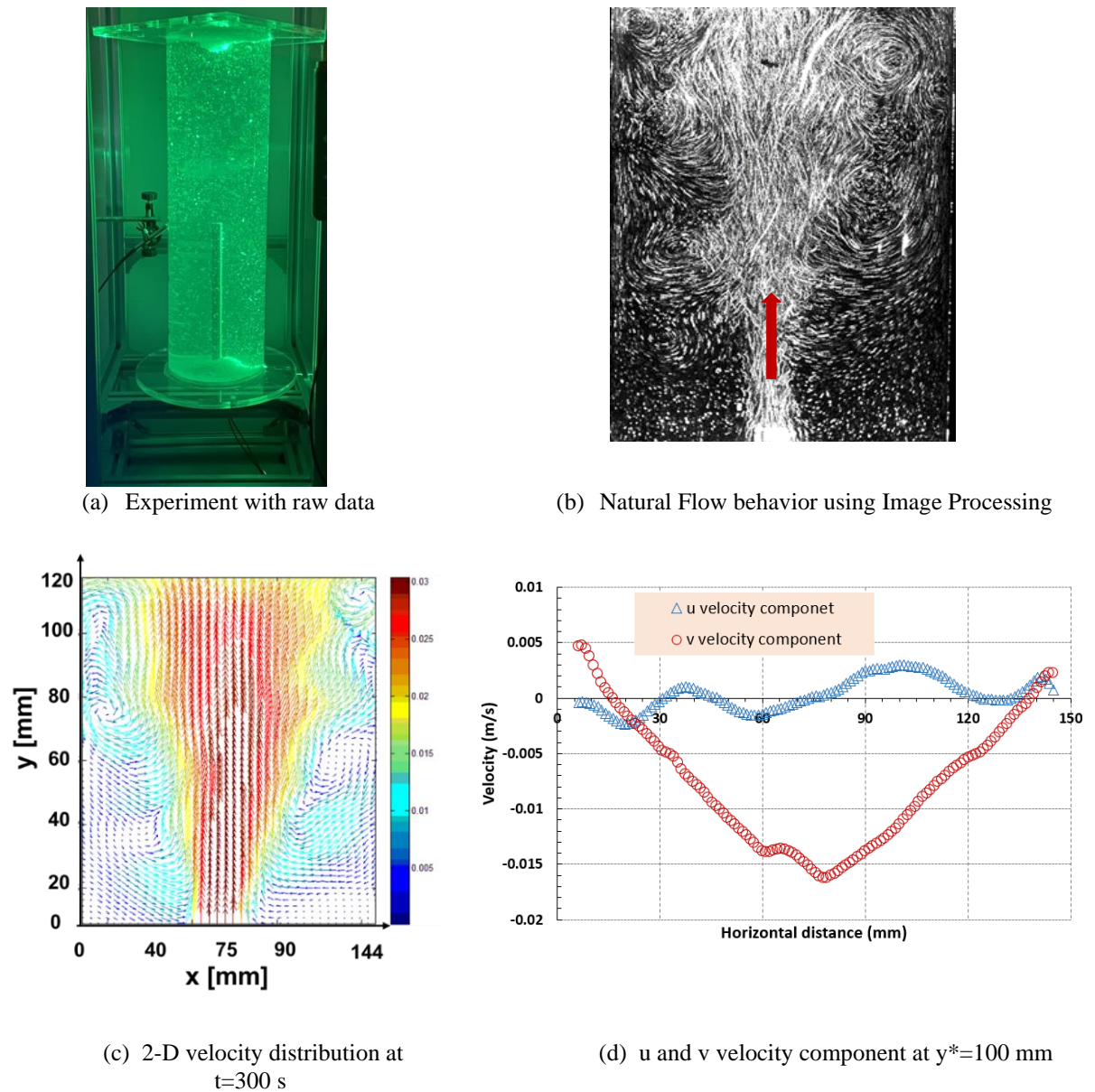

Fig. 4. Experimental data of natural convection recorded by the camera (a), (b) visualization using image processing, (c) the velocity distribution using PIV and (d) the two components of velocity at 300 s.

The simulation results of temperature showed good agreement with experimental data. Besides, the averaged velocity profile from the simulation confirmed that the upward flow was located at the center of the

pool where the heater rod was located. The main upward flow was observed along the heater rod, and the flow behavior close to the container wall moved with a low velocity of less than 0.005 m/s.

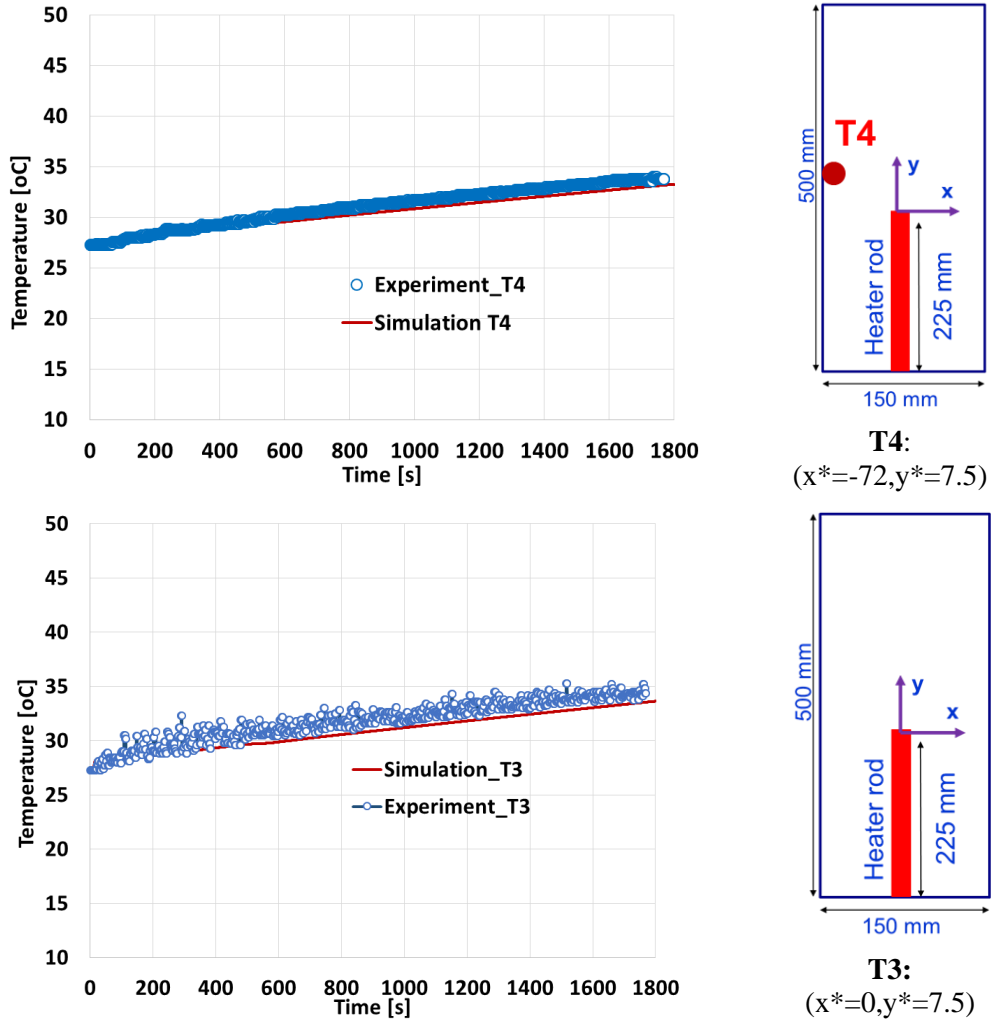

Fig. 5. The comparison of the history of temperature at T3 T4 locations

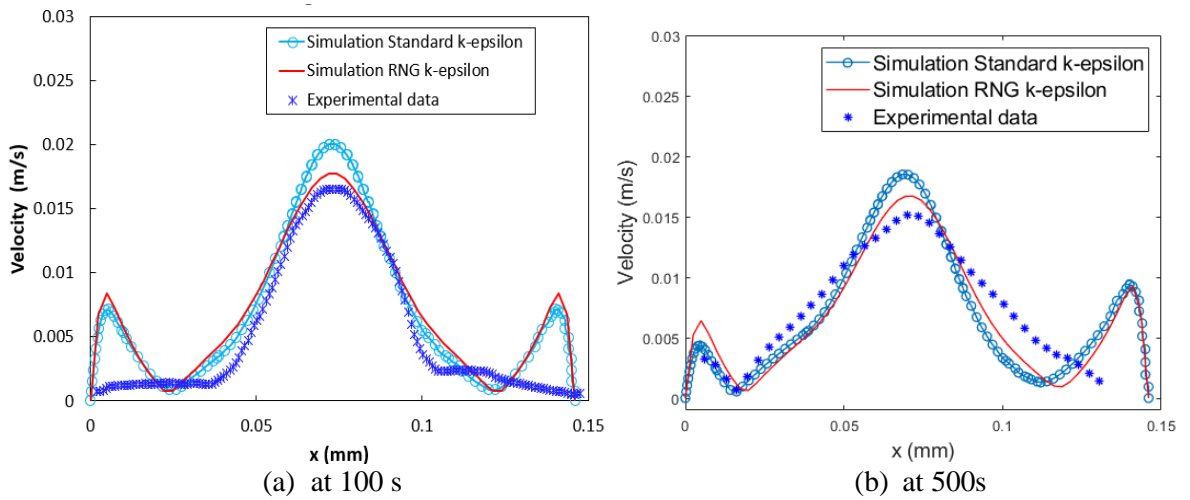

Fig. 7. Comparison of the velocity profile at 100 s, 500 s between CFD and PIV method at 5 cm above the heater rod

SIMULATION OF NATURAL CONVECTION FLOW FOR VERTICAL HEATED ROD BY USING...

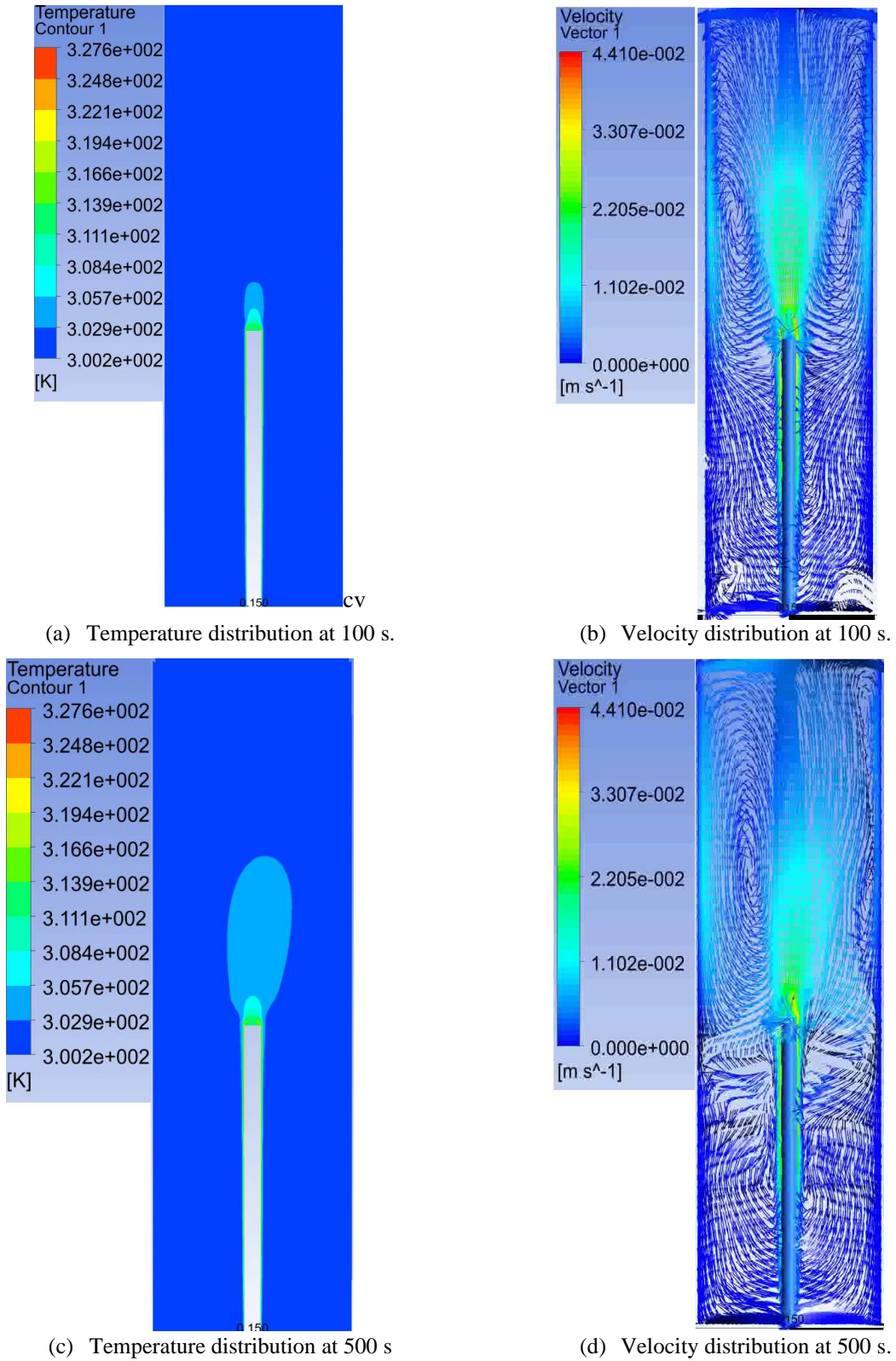

Fig. 6. Simulation results of velocity and temperature distribution at different times

Since the natural flow fluctuated, it was not easy to compare the results in averaging. Therefore, in Fig. 7, the velocity profile at 100 s and 500 s were selected to validate the simulation results. For the PIV method, the velocity profile recorded for 30 s corresponding to 18000 frames was averaged for comparison. The flow vertically ascended, thus the vertical velocity profile was selected for comparison.

As a result, the flow was upward at the center near the rod. The velocity far the rod was smaller than the flow close to the heater rod. The Fig. 7a and Fig. 7b showed a good agreement between the simulation and experiment by using 2 k-epsilon turbulence model (standard, and RNG). The density of water close to the heater rod was quickly decreased due to the high temperature of rod surface and moved to the colder region caused by the buoyancy force. That was the typical natural flow behavior. The water descended when reaching the upper wall. Therefore, in the upper region of heater rod and the upper part of the container, the upward and downward flow induced a very complicate flow behavior. Both simulation result and experimental data showed clearly that the plume was mainly concentrated on the the region close to the heater rod.

However, near-wall flows were different. As the experimental data using image processing, the fluid was broken into small eddies while the CFD simulation using RANS maintains a big vortex like a laminar flow. That made the difference between the simulation and experimental data.

IV. CONCLUSIONS

The CFD using Ansys/Fluent was successfully applied to simulate the natural convection induced by vertical heater rod. The simulation considered the temperature dependence of physical properties and the

utilization of coupled scheme algorithm. Besides, the k-epsilon turbulence models of ANSYS/Fluent were appropriate to simulate the natural flow. In order to validate the simulation results, the PIV technique was applied to measure the 2-dimensional velocity profile. The simulation results agreed well with experimental data such as velocity distribution measured by using the PIV method. The simulated flow behavior was well predicted in comparing with experimental data in which the complicated flow in the middle part of the container caused by the interaction between the upward flow and the downward flow on the top wall. The comparison showed similar phenomena between simulation and experimental data. Additionally, the pointwise temperature matched well between the simulation and experiment.

This model and the simulation approach would be further applied for the more complicated fuel assembly which used several fuel element layers in the research reactor.

REFERENCES

- [1]. IAEA-TECDOC-1474, Natural circulation in water cooled nuclear power plants Phenomena, models, and methodology for system reliability assessments, 2005.
- [2]. K. Kitamura , A. Mitsuishi, T. Suzuki, F. Kimura, "Fluid flow and heat transfer of natural convection induced around a vertical row of heated horizontal cylinders", *Int. J. Heat and Mass Transfer* 92 (2016) 414-429.
- [3]. S. Grafsrønningen, A. Jensen, B.A.P. Reif, "PIV investigation of the buoyant plume from natural convection heat transfer above a horizontal heated cylinder," *Int. J.Heat Mass Transf.* 54 (23–24) (2011), pp. 4975–4987.
- [4]. Park H, Park J, Jung S.Y: Measurements of velocity and temperature fields in natural convective flows, *Int. Journal of Heat and Mass Transfer* 139 (2019), 293–302.

- [5]. S. Kim, S.U. Ryu, D.-J. Euh, C.-H. Song, “Experimental study on the thermal stratification in a pool boiling with a horizontal heat source”, *Ann. Nucl. Energy*, 106 (2017), pp. 235–246.
- [6]. Nhi-Dien Nguyen, Kien-Cuong Nguyen, Ton-Nghiem Huynh, Doan-Hai-Dang Vo and Hoai-Nam Tran, Conceptual Design of a 10 MW Multipurpose Research Reactor Using VVR-KN Fuel”, *Science and Technology of Nuclear Installations*, Vol. 2020, Volume 2020, Article ID 7972827, 11 p.p.
- [7]. Foroozani N, Krasnov D & Jörg Schumacher, “Turbulent convection for different thermal boundary conditions at the plates” , *J. Fluid Mech.* 907 (2021), A27
- [8]. Seok-Ki Choi, Seo-O Kim, Eui-Kwang Kim, Hoon-Ki choi, “Evaluation of the K-epsilon-VV-F Turbulence Model for Natural Convection in a rectangular cavity”, *Journal of Computational Fluids Engineering*, 2002.
- [9]. Boz Z, Erdogdu F & Mustafa Tutar, “Effects of mesh refinement, time step size and numerical scheme on the computational modeling of temperature evolution during natural-convection heating, *Journal of Food Engineering* 123 (2014), 8–16.